



WEBSITE <http://biz.LGservice.com>
E-MAIL <http://www.LGservice.com/techsup.html>

Room Air Conditioner

SERVICE MANUAL

CAUTION

- BEFORE SERVICING THE UNIT, READ THE SAFETY PRECAUTIONS IN THIS MANUAL.
- ONLY FOR AUTHORIZED SERVICE.

**MODEL: LP6000ER
LP7000R**

CONTENTS

1. PREFACE

1.1 SAFETY PRECAUTIONS.....	2
1.2 INSULATION RESISTANCE TEST.....	2
1.3 SPECIFICATIONS.....	3
1.4 FEATURES.....	4
1.5 CONTROL LOCATIONS	4

2. DISASSEMBLY INSTRUCTIONS

2.1 MECHANICAL PARTS	5
2.1.1 FRONT GRILLE	5
2.1.2 TOP COVER	5
2.1.3 CABINET	5
2.1.4 CONTROL BOX	5
2.2 AIR HANDLING PARTS	6
2.2.1 AIR GUIDE AND CROSS FLOW FAN ...	6
2.2.2 FAN AND SHROUD	6
2.2.3 INDOOR FAN MOTOR.....	7
2.2.4 AIR GUIDE LOWER	7
2.3 ELECTRICAL PARTS.....	7
2.3.1 OVERLOAD PROTECTOR	7
2.3.2 COMPRESSOR.....	7
2.3.3 CAPACITOR.....	8
2.3.4 POWER CORD	8
2.3.5 OUTDOOR MOTOR	9
2.4 REFRIGERATION CYCLE	9
2.4.1 CONDENSER.....	9

2.4.2 EVAPORATOR.....	9
2.4.3 CAPILLARY TUBE	9

3. INSTALLATION

3.1 HOW TO INSTALL THE UNIT.....	12
3.2 CHECKING INSTALLATION	12
3.3 WINDOW REQUIREMENTS	12
3.4 INSTALLATION KITS CONTENTS	12
3.5 SUGGESTED TOOL REQUIREMENTS	13
3.6 HOW TO INSTALL	13
3.7 REMOVAL FROM WINDOW.....	16

4. TROUBLESHOOTING GUIDE

4.1 OUTSIDE DIMENSIONS	16
4.2 PIPING SYSTEM.....	17
4.3 TROUBLESHOOTING GUIDE	18

5. SCHEMATIC DIAGRAM

5.1 CIRCUIT DIAGRAM	27
5.2 ELECTRONIC CONTROL DEVICE.....	28
5.3 COMPONENTS LOCATION(FOR AC P.C.B ASM)...	29
5.4 COMPONENTS LOCATION(FOR DC P.C.B ASM) ..	29

6. EXPLODED VIEW

7. REPLACEMENT PARTS LIST

1. PREFACE

This SERVICE MANUAL provides various service information, including the mechanical and electrical parts etc. This room air conditioner was manufactured and assembled under a strict quality control system. The refrigerant is charged at the factory. Be sure to read the safety precautions prior to servicing the unit.

1.1 SAFETY PRECAUTIONS

1. When servicing the unit, set the ROTARY SWITCH or POWER SWITCH to OFF and unplug the power cord.
2. Observe the original lead dress.
If a short circuit is found, replace all parts which have been overheated or damaged by the short circuit.
3. After servicing the unit, make an insulation resistance test to protect the customer from being exposed to shock hazards.

1.2 INSULATION RESISTANCE TEST

1. Unplug the power cord and connect a jumper between 2 pins (black and white).
2. The grounding conductor (green) is to be open.
3. Measure the resistance value with an ohm meter between the jumpered lead and each exposed metallic part on the equipment at all the positions (except OFF) of the ROTARY SWITCH.
4. The value should be over 1MΩ.

1.3 SPECIFICATIONS

1.3.1 FOR LP6000ER/LP7000R

ITEMS		MODELS	
		LP6000ER	LP7000R
POWER SUPPLY		115V, 60Hz	
COOLING CAPACITY	(Btu/h)	6,000	7,000
INPUT	(W)	560	700
RUNNING CURRENT	(A)	5.2	6.5
E.E.R	(BTU/W·h)	10.7	10.0
OPERATING CONDITION	INDOOR (°C)	26.7(DB)*	19.4(WB)**
	OUTDOOR (°C)	35(DB)*	23.9(WB)**
REFRIGERANT (R-22) CHARGE		435g(15.3 oz)	350g(12.3 oz)
EVAPORATOR		2 ROW 9 STACKS, SLIT FIN TYPE	
CONDENSER		2 ROW 14 STACKS, LOUVER FIN TYPE	
FAN, INDOOR		CROSS FLOW FAN	
FAN, OUTDOOR		AXIAL FAN	
FAN SPEEDS, FAN/COOLING		3/3	
FAN MOTOR		4 POLES	
OPERATION CONTROL		REMOTE CONTROLLER	
ROOM TEMP. CONTROL		THERMISTOR	
AIR DIRECTION CONTROL		VERTICAL LOUVER (RIGHT & LEFT)	
		HORIZONTAL LOUVER (UP & DOWN)	
CONSTRUCTION		TOP-DOWN CHASSIS	
PROTECTOR	COMPRESSOR	OVERLOAD PROTECTOR	
	FAN MOTOR	INTERNAL THERMAL PROTECTOR	
POWER CORD		3 WIRE WITH GROUNDING	
		ATTACHMENT PLUG (CORD-CONNECTED TYPE)	
DRAIN SYSTEM		DRAIN PIPE SPLASHED BY FAN SLINGER	
NET WEIGHT	(lbs/kg)	55/25	57/26
OUTSIDE DIMENSION	(inch)	23 ⁵ / ₈ x 12 x 18 ¹ / ₃₂	
(W x H x D)	(mm)	600 x 305 x 458	

* DB: Dry Bulb

** WB: Wet Bulb

1.4 FEATURES

- Designed for COOLING ONLY.
- Powerful and quiet cooling.
- Simple installation and service.
- Low air-intake, top cool-air discharge.
- Built-in adjustable THERMISTOR
- Washable one-touch filter
- Compact size
- Reliable and efficient rotary compressor.

1.5 CONTROL LOCATIONS

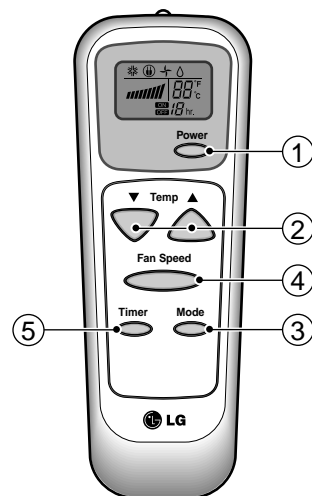
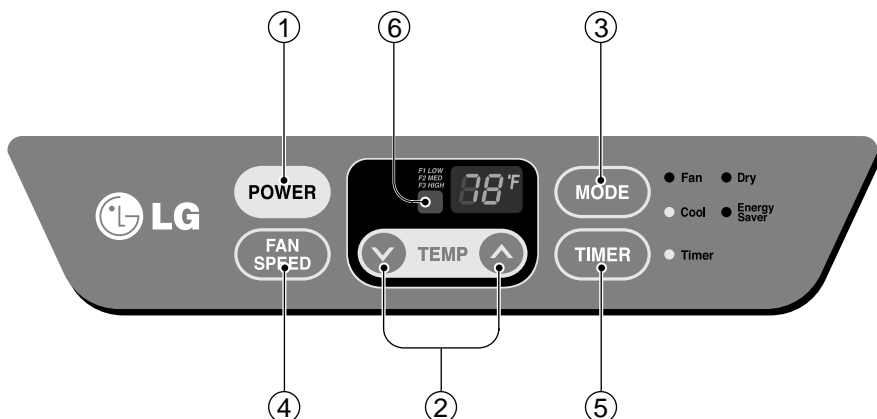

Precaution: The Remote Control unit will not function properly if bright light strikes the sensor window of the air conditioner or if there are obstacles between the Remote Control unit and the air conditioner.

1 POWER

- To turn the air conditioner ON, push this button. To turn the air conditioner OFF, push the button again.
- This button takes priority over any other button.
- When you first turn it on, the unit is in cool mode, high fan speed, temperature setting at 72°F.

2 TEMPERATURE SETTING

- Use this button to automatically control the temperature of the room.
The temperature can be set within a range of 60°F to 86°F by increments of 1°F.

3 MODE

- Every time you push this button, it will cycle through COOL, ENERGY SAVER, FAN and DRY.
- ENERGY SAVER
- The fan stops when the compressor stops cooling. Approximately every 3 minutes the fan will turn on and the unit will check the room air to determine if cooling is needed.

4 FAN SPEED

- Every time you push this button, it advances the setting as follows: {High(F3) → Low(F1) → Med(F2) → High(F3)}

5 TIMER

- SHUT-OFF TIME
- You will usually use shut-off time while you sleep.
- With unit running, use Timer to set number of hours until shut-off.
- For your sleeping comfort, once Time is set, the Temperature setting will raise 2°F after 30 min, and 2°F after another 30 min.
- Every time you push Timer button, it advances the Timer setting as follows: 1 Hour → 2 Hours → etc. → 12 Hours maximum.
- START TIME
- While unit not running, use timer to set number of hours before unit starts.
- Every time you push Timer button, it advances the Timer setting as follows: 1 Hour → 2 Hours → etc. → 12 Hours maximum.

6 REMOTE CONTROL SENSOR

AUTO RESTART

When power is restored after an electrical power failure, the unit will begin to run at its last setting.

2. DISASSEMBLY INSTRUCTIONS

2.1 MECHANICAL PARTS

2.1.1 FRONT GRILLE

1. Unplug the unit from source of power.
2. Remove the 2 screws securing the front Grille.(See Figure 1)
3. Push the grille up from the bottom and pull the top of the grille way from the cabinet to lift the top tabs out of their slots.(See Figure 2)
4. Disconnect display connector.

2.1.2 TOP COVER

1. Disconnect the unit from the power source.
2. Remove the front grille.(Refer to section 2.1.1)
3. Remove curtains on both side.
4. Remove 5 screws that secure the top cover to the cabinet.(See Figure 3)

2.1.3 CABINET

1. Disconnect the unit from the power source.
2. Remove the front grille. (Refer to section 2.1.1)
3. Remove the top cover. (Refer to section 2.1.2)
4. Remove 4 screws that secure the cabinet to the base pan. (See Figure 4)
5. Remove the cabinet.
6. Re-install by referring to the procedures above.

2.1.4 CONTROL BOX

1. Disconnect the unit from the power source.
2. Remove the front grille. (Refer to Section 2.1.1)
3. Remove the screw that fastens the power cord.
4. Remove the grounding screw from the evaporator channel and remove the thermistor from the evaporator fin.
5. Remove the 2 screws that fasten the control box cover and open the control box cover.(See Figure 5)
6. Remove the housing that connects motor and wires come form compressor.
7. Remove the screw that secures the control box and base pan.
8. Remove the 2 screws that secure the control box and motor mount.(See Figure 6)
9. Move the control box upward.

Figure 1

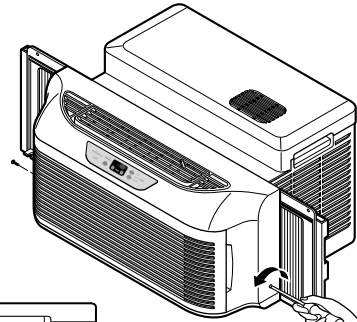

Figure 2

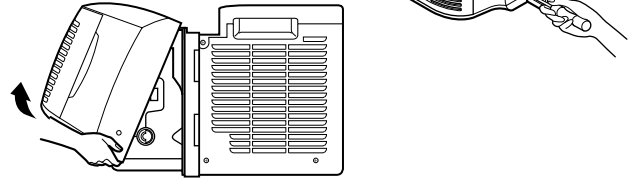

Figure 3

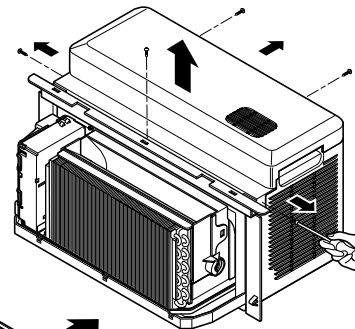

Figure 4

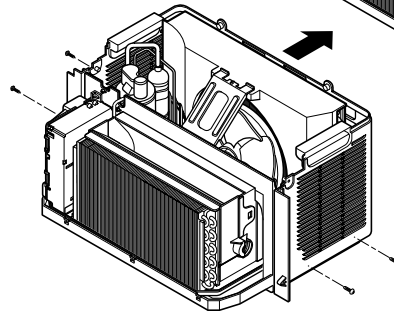

Figure 5

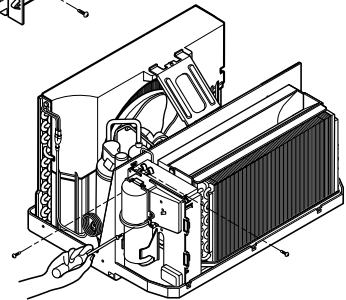
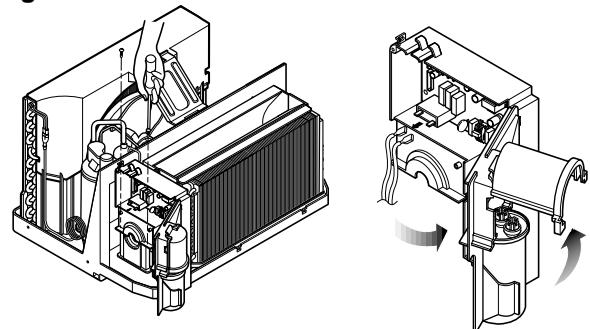

Figure 6



2.2 AIR HANDLING PARTS

2.2.1 AIR GUIDE UPPER AND CROSS FLOW FAN

1. Disconnect the unit from the power source.
2. Remove the front grille.
(Refer to Section 2.1.1)
3. Remove the top cover. (Refer to Section 2.1.2)
4. Remove the cabinet. (Refer to Section 2.1.3)
5. Remove the control box. (Refer to Section 2.1.4)
6. Move the evaporator forward, pulling it upward slightly.
7. Pull the air guide upper and remove it. (See Figure 7)
8. Loosen the bolt securing the cross flow fan to the motor (do not remove).
9. Pull the cross flow fan and remove it.
10. Re-install by referring to the procedures above.

Figure 7

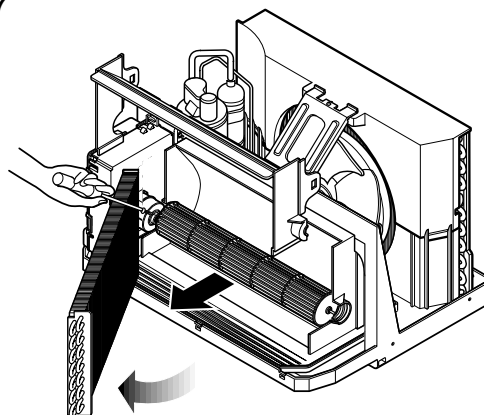
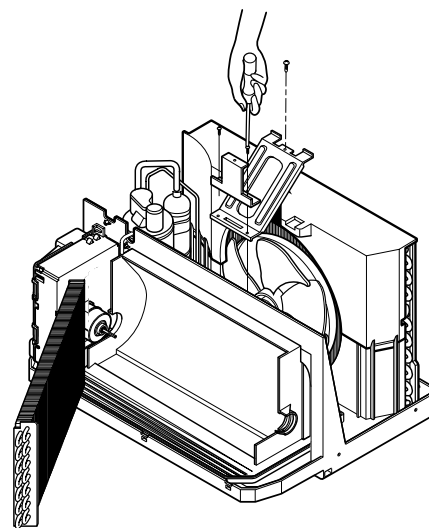

Figure 8



2.2.2 FAN AND SHROUD

1. Disconnect the unit from the power source.
2. Remove the front grille. (Refer to Section 2.1.1)
3. Remove the top cover. (Refer to Section 2.1.2)
4. Remove the cabinet. (Refer to Section 2.1.3)
5. Remove 3 screws which fasten the brace and the bracket. (See Figure 8)
6. Remove the brace and the bracket.
7. Remove 4 screws which fasten the condenser channel, shroud and base pan.
8. Move the shroud upward and remove it.
9. Move the condenser forward, pulling it slightly upward.
10. Remove the clamp with a hand plier which secures the fan. (See Figure 9)
11. Remove the fan.
14. Re-install by referring to the procedures above.

Figure 9

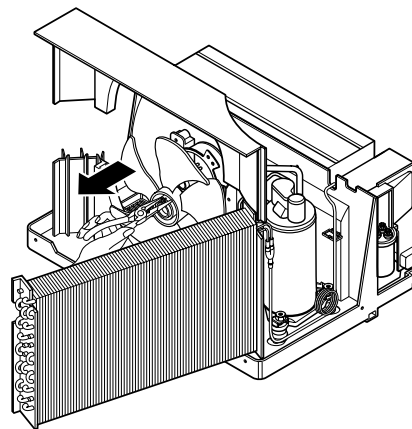

2.2.3 INDOOR FAN MOTOR

1. Disconnect the unit from the power source.
2. Remove the front grille. (Refer to Section 2.1.1)
3. Remove the control box.
(Refer to Section 2.1.4)
4. Remove the air guide upper and cross flow fan.
(Refer to Section 2.2.1)
5. Remove the motor.(See Figure 10)
6. Re-install by referring to the procedures above.

Figure 10

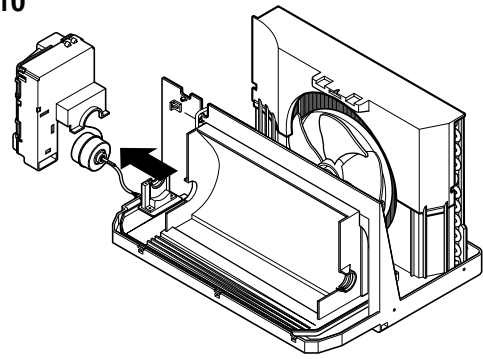

2.2.4 AIR GUIDE LOWER

1. Disconnect the unit from the power source.
2. Remove the front grille. (Refer to Section 2.1.1)
3. Remove the top cover. (Refer to Section 2.1.2)
4. Remove the control box.
(Refer to Section 2.1.4)
5. Remove the air guide upper and cross flow fan.
(Refer to Section 2.2.1)
6. Remove the motor. (Refer to Section 2.2.3)
7. Remove 2 screws which fasten the mount motor and remove mount motor. (See Figure 11)
8. Remove the fan and shroud.(Refer to Section 2.2.2)
9. Remove 3 screws that secure the air guide to the base pan. (See Figure 11)
10. Pull the airguide toward yourself. (See Figure 12)
11. Re-install by referring to the procedures above.

Figure 11

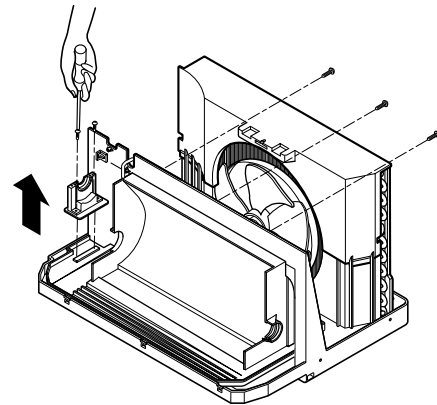
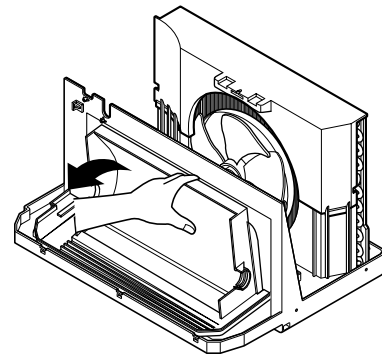

Figure 12



2.3 ELECTRICAL PARTS

2.3.1 OVERLOAD PROTECTOR

1. Remove the front grille, top cover and cabinet.
(Refer to Section 2.1)
2. Remove the nut which fastens the terminal cover.
3. Remove the terminal cover.
4. Remove all the leads from the overload protector.
5. Remove the overload protector.
6. Re-install the components by referring to the removal procedure above.
(See Figure 13 and 14)

Figure 13

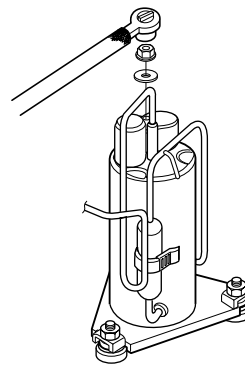
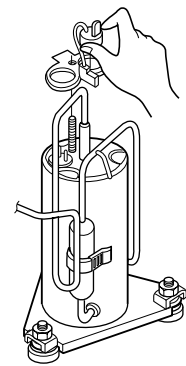

Figure 14



2.3.2 COMPRESSOR

1. Remove the front grille, top cover and cabinet. (Refer to Section 2.1)
2. Discharge the refrigerant system using a Freon™ Recovery System.
If there is no valve to attach the recovery system, install one (such as a Watco A-1) before venting the Freon™. Leave the valve in place after servicing the system.
3. Remove the overload protector. (Refer to section 2.3.1)
4. After purging the unit completely, unbraid the suction and discharge tubes at the compressor connections.
5. Remove the 3 nuts and the 3 washers that fasten the compressor. (See Figure 15)
6. Remove the compressor.
7. Re-install the components by referring to the removal procedure, above.

Figure 15

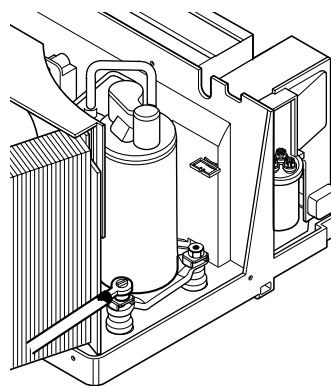

2.3.3 CAPACITOR

1. Remove the front grille. (Refer to Section 2.1.1)
2. Open the capacitor cover. (See Figure 16)
3. Remove all the leads of capacitor terminals.
4. Re-install the components by referring to the removal procedure above.

Figure 16

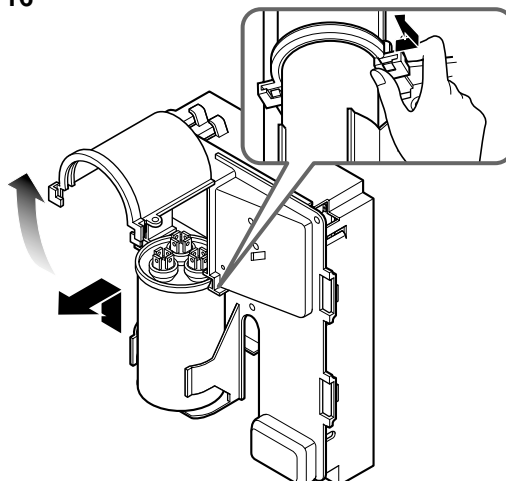

2.3.4 POWER CORD

1. Remove the control box. (Refer to section 2.1.4)
2. Open the control box cover.
3. Disconnect two leads from the capacitor and relay.
4. Remove a screw securing the clip with cord to the control box.
5. Pull out the power cord.
6. Re-install by referring to procedures above. (Use only one ground-marked hole \oplus for ground connection.)
7. If the supply cord of this appliance is damaged, it must be replaced by the special cord. (The special cord means the cord that has the same specification marked on the supply cord attached at the unit.)

Figure 17

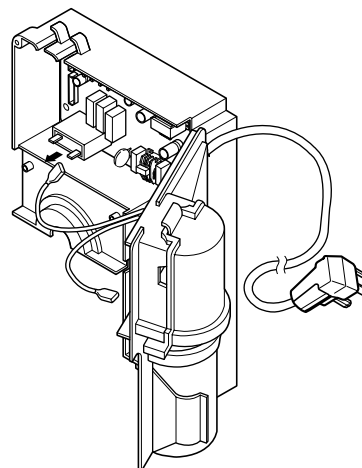

2.3.5 OUTDOOR MOTOR

1. Remove the front grille. (Refer to section 2.1.1)
2. Remove the top cover. (Refer to section 2.1.2)
3. Remove the cabinet. (Refer to section 2.1.3)
4. Remove the fan and shroud. (Refer to section 2.2.2)
5. Remove the 3 screws which fasten the motor from the mount motor. (See Figure 18)
6. Open the capacitor cover (Refer to section 2.3.3)
7. Disconnect the outdoor motor housing.
8. Remove the motor.
9. Re-install the components by referring to the removal procedure, above.

Figure 18

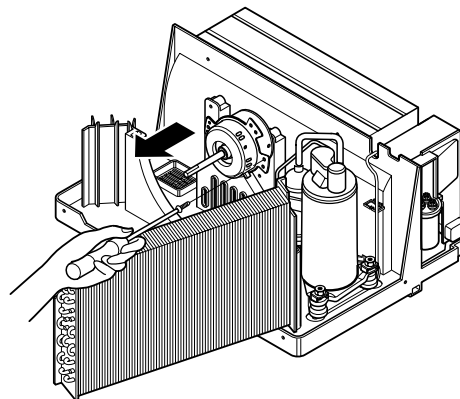

2.4 REFRIGERANT CYCLE

2.4.1 CONDENSER

CAUTION

Discharge the refrigerant system using a Freon™ Recovery System.

If there is no valve to attach the recovery system, install one (such as a WATCO A-1) before venting the Freon™. Leave the valve in place after servicing the system.

1. Remove the front grille. (Refer to Section 2.1.1)
2. Remove the top cover. (Refer to Section 2.1.2)
3. Remove the cabinet. (Refer to Section 2.1.3)
4. Remove the shroud. (Refer to Section 2.2.2)
5. Discharge the refrigerant by using a refrigerant recovery system.
6. After discharging the refrigerant completely, unbraid the interconnecting tube at the condenser connections.
7. Remove the condenser.
8. Re-install by referring to the procedures above.

2.4.2 EVAPORATOR

1. Remove the front grille. (Refer to Section 2.1.1)
2. Remove the top cover. (Refer to Section 2.1.2)
3. Remove the cabinet. (Refer to Section 2.1.3)
4. Remove the control box. (Refer to Section 2.1.4)
5. Discharge the refrigerant by using a refrigerant recovery system.
6. After discharging the refrigerant completely, unbraid the interconnecting tube at the condenser connections.
7. Remove the evaporator.
8. Re-install by referring to the procedures above.

Figure 19

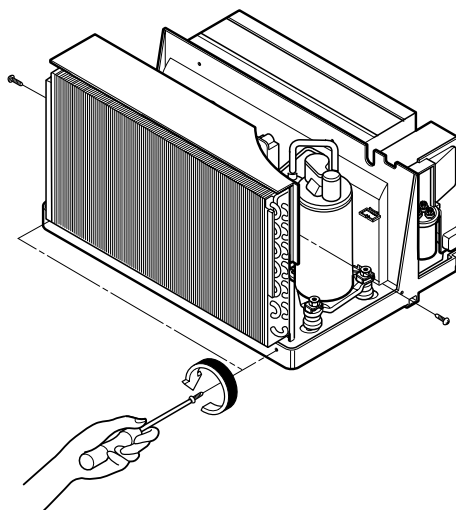

2.4.3 CAPILLARY TUBE

1. Remove the front grille. (Refer to Section 2.1.1)
2. Remove the top cover. (Refer to Section 2.1.2)
3. Remove the cabinet. (Refer to Section 2.1.3)
4. Remove the control box. (Refer to Section 2.1.4)
5. Discharge the refrigerant by using a refrigerant recovery system.
6. After discharging the refrigerant completely, unbraid the interconnecting tube of the capillary tube.
7. Remove the capillary tube.
8. Re-install by referring to the procedures above.

NOTES

— Replacement of the refrigerant.

1. When replacing the refrigerant, be sure to discharge the refrigerant system using a Freon™ recovery System.
If there is no valve to attach the recovery system, install one (such as a WATCO A-1) before venting the Freon™. Leave the valve in place after servicing the system.
2. After discharging the unit completely, remove the desired component, and unbraid the pinch-off tubes.
3. Braze service valves into the pinch-off tube ports, leaving the valves open.
4. Braze the pinch-off tubes with Service valves.
5. Evacuate as follows.
 - 1) Connect the vacuum pump, as illustrated figure 20A.
 - 2) Start the vacuum pump, slowly open manifold valves A and B with two full turns counterclockwise and leave the valves open. The vacuum pump is now pulling through valves A and B up to valve C by means of the manifold and entire system.

CAUTION

If high vacuum equipment is used, just crack valves A and B for a few minutes, then open slowly with the two full turns counterclockwise. This will keep oil from foaming and being drawn into the vacuum pump.

- 3) Operate the vacuum pump for 20 to 30 minutes, until 600 microns of vacuum is obtained. Close valves A and B, and observe vacuum gauge for a few minutes. A rise in pressure would indicate a possible leak or moisture remaining in the system. With valves A and B closed, stop the vacuum pump.
- 4) Remove the hose from the vacuum pump and place it on the charging cylinder. See figure 20B.
Open valve C.
Discharge the line at the manifold connection.
- 5) The system is now ready for final charging.

6. Recharge as follows :

- 1) Refrigeration cycle systems are charged from the High-side. If the total charge cannot be put in the High-side, the balance will be put in the suction line through the access valve which you installed as the system was opened.
- 2) Connect the charging cylinder as shown in figure 20B.
With valve C open, discharge the hose at the manifold connection.
- 3) Open valve A and allow the proper charge to enter the system. Valve B is still closed.
- 4) If more charge is required, the high-side will not take it. Close valve A.
- 5) With the unit running, open valve B and add the balance of the charge.
 - a. Do not add the liquid refrigerant to the Low-side.
 - b. Watch the Low-side gauge; allow pressure to rise to 30 lbs.
 - c. Turn off valve B and allow pressure to drop.
 - d. Repeat steps b. and c. until the balance of the charge is in the system.
- 6) When satisfied the unit is operating correctly, use the pinch-off tool with the unit still running and clamp on to the pinch-off tube. Using a tube cutter, cut the pinch-off tube about 2 inches from the pinch-off tool. Use sil-fos solder and solder pinch-off tube closed. Turn off the unit, allow it to set for a while, and then test the leakage of the pinch-off connection.

Equipment needed: Vacuum pump, Charging cylinder, Manifold gauge, Brazing equipment. Pin-off tool capable of making a vapor-proof seal, Leak detector, Tubing cutter, Hand Tools to remove components, Service valve.

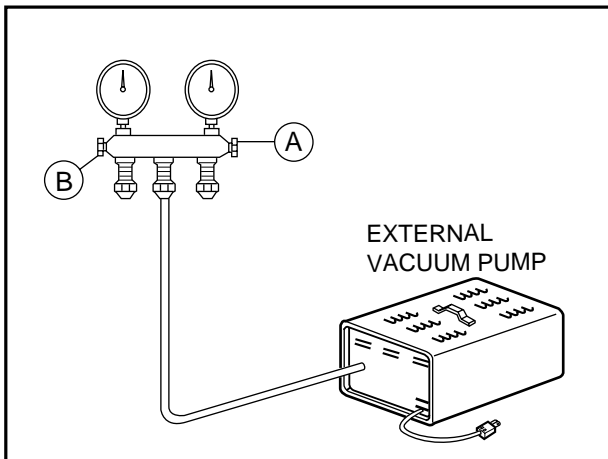
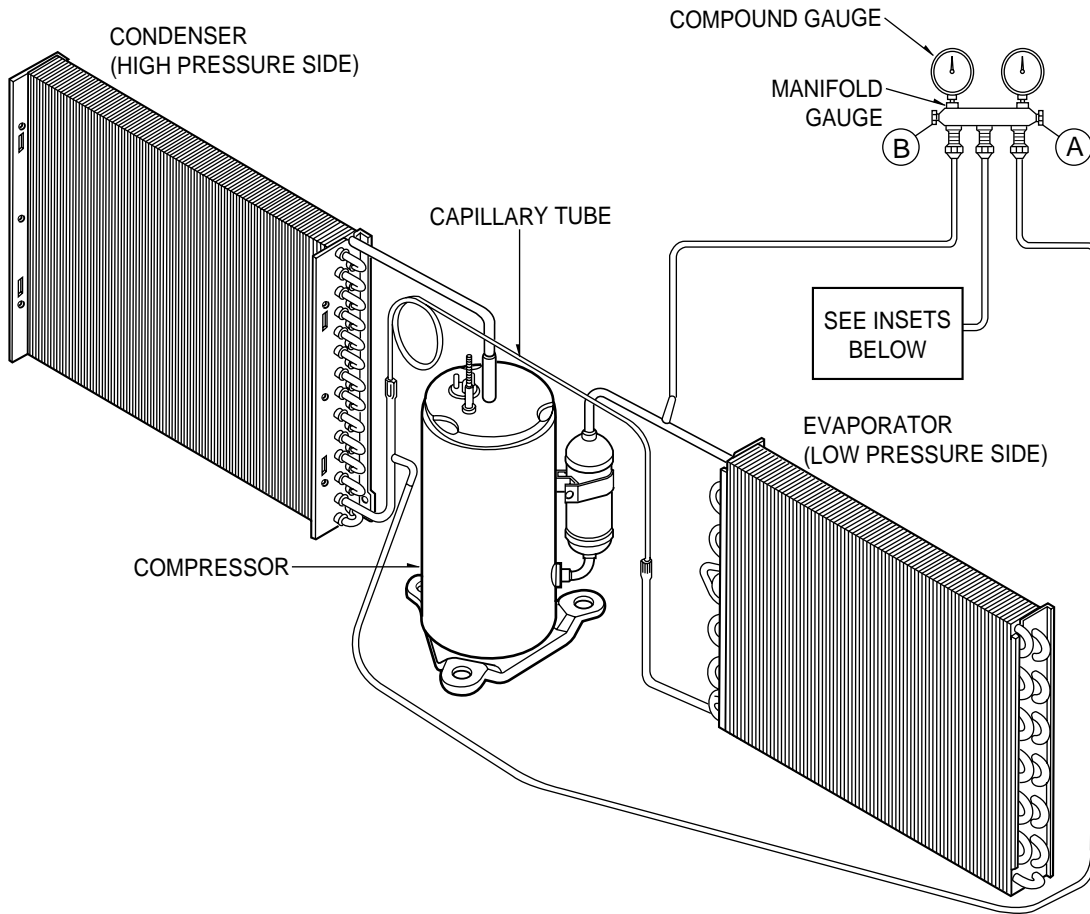

Figure 20A-Pulling Vacuum

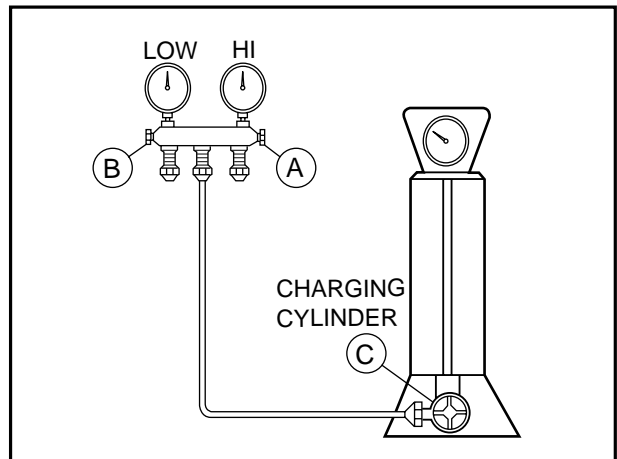

Figure 20B-Charging

3. INSTALLATION

3.1 HOW TO INSTALL THE UNIT

1. To prevent vibration and noise, make sure the unit is installed securely and firmly.
2. Install the unit where the sunlight does not shine directly on the unit.
3. The outside of the cabinet must extend outward and there should be no obstacles, such as a fence or wall, within 20" from the back of the cabinet because it will prevent heat radiation of the condenser.
Restriction of outside air will greatly reduce the cooling efficiency of the air conditioner.

CAUTION: All side louvers of the cabinet must remain exposed to the outside of the structure.

4. Install the unit a little slanted so the back is slightly lower than the front (about 1/4").
This will force condensed water to flow to the outside.
5. Install the unit with the bottom about 30"~60" above the floor level.

Figure 21

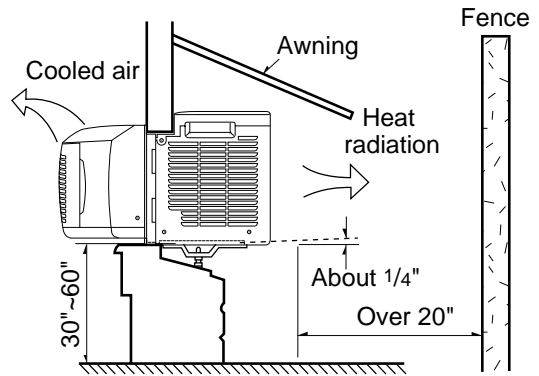

3.2 CHECK OF INSTALLATION

The setting conditions must be checked prior to initial starting.

The undermentioned items are especially important checking points when the installation is finished.

1. Grounding wire (Green or Green and Yellow) is provided in the power cord. The green wire must be grounded.
2. Connect to a single-outlet 15A circuit.
(or 21A circuit for Electric Heater Model)
3. To avoid vibration or noise, make sure the air conditioner is installed securely.
4. Avoid placing furniture or draperies in front of the air inlet and outlet.

3.3 WINDOW REQUIREMENTS

NOTE: All supporting parts should be secured to firm wood, masonry, or metal.

1. This unit is designed for installation in standard double hung windows with actual opening widths from 26" to 39 3/8".
2. The top and bottom window sash must open sufficiently to allow a clear vertical opening of 12" from the bottom.

Figure 22

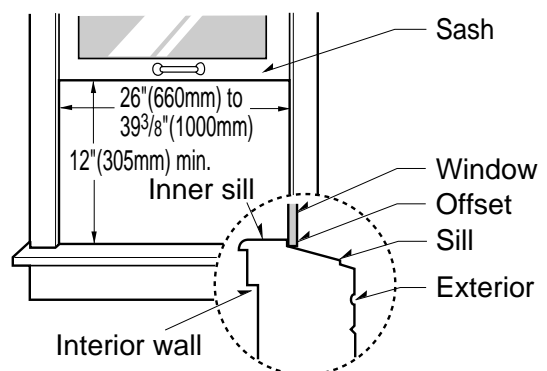

3.4 INSTALLATION KITS CONTENTS

ITEM	NAME OF PARTS	Q'TY
A	SUPPORT, BRACKET	1
B	LEVELING BOLT	1
C	LEVELING BOLT	1
D	SCREW: 5/8"	2
E	SCREW: 5/8"	5
F	FOAM SEAL	1
G	FOAM STRIP	1
H	L BRACKET	1

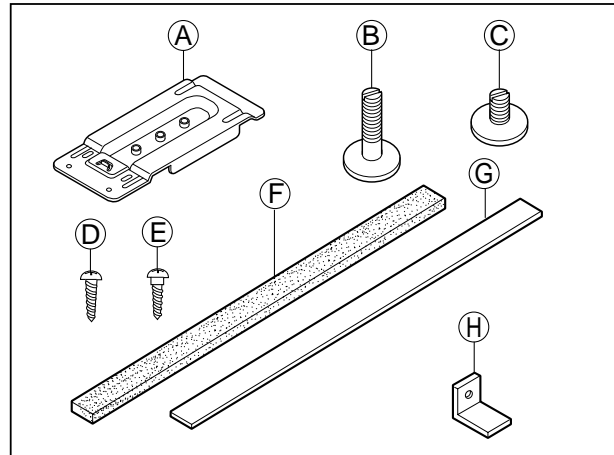

3.5 SUGGESTED TOOL REQUIREMENTS

SCREWDRIVER(Phillips and Flathead), RULER, KNIFE, HAMMER, PENCIL, LEVEL

3.6 HOW TO INSTALL

⚠ CAUTION

To avoid the possibility of personal injury, unplug power to unit before installing or servicing.

Carefully remove air conditioner from carton, check for possible shipping damage. Pick a location which will allow you to blow the cold air into the area you want. Windows used for installation must be strong enough to support the weight of the air conditioner. Good installation with special attention to the proper position of the unit will lessen the chance that service will be needed.

When cooling more than one room, installation location is very important. To cool your rooms, cold air must be blown from the air conditioner in a straight path. If air conditioner is blocked by a storm window frame, see Step 7 and 8 on Page 14 before beginning to install.

1. Cut the FOAM STRIP (ITEM G) to fit the underside of the window sash. Open the window, peel off the backing and attach the FOAM STRIP as shown in Figure 23.
2. Mark center line with pencil on the center of the inner sill, as shown in Figure 24.

Figure 23

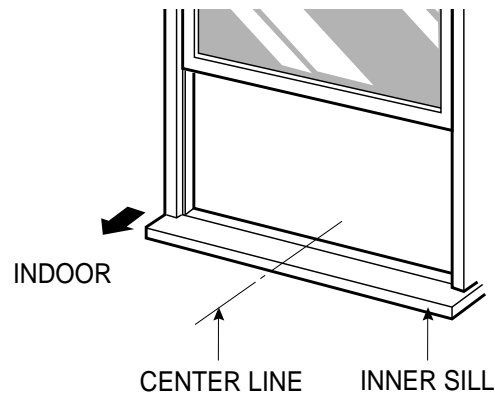
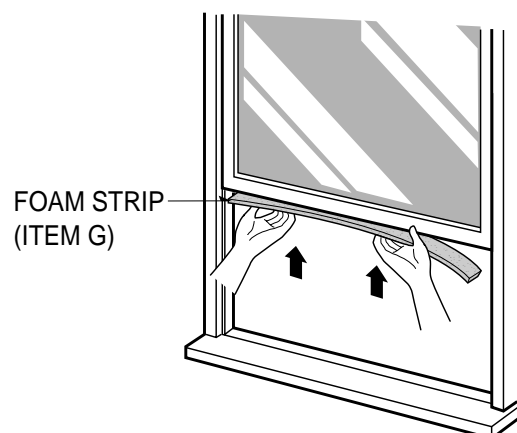

Figure 24



- Install support bracket on window. See Figure 25. Install leveling bolt up through bottom side of support bracket. You can choose a short bolt (ITEM C) or a long one (ITEM B) according to window type. Also, you should select the position of hole on bracket. Position bracket on sill 1 inch (25.4mm) to left of center line of window (See Figure 25). Fasten bracket loosely to sill with screws (ITEM D) provided. Adjust leveling bolt so that the air conditioner will be installed with a very slight tilt (about 1/4") downward toward the outside for proper drainage. Tighten bracket screws.



CAUTION

Failure to securely install support bracket may result in unit falling from window if window sash is raised after unit is installed. This could result in personal injury.

4. INSTALL THE AIR CONDITIONER IN THE WINDOW

- Carefully lift the air conditioner and slide it into the open window. Be careful not to hurt waist in this operation.
- Use the two hand grips on top sides of unit to lift unit.
- Make sure that support bracket is inserted in the pocket under base fan, and that curtain frame guide is stopped by stopper on the support bracket as shown in Figure 28.

NOTE: When unit is properly centered and pushed outward to correct bracket location, you will feel unit drop securely in place on the support bracket. Hold unit firmly during this procedure.

- Lower top window sash all the way down so that sash sits firmly in top channel of unit and expandable curtain frames.



CAUTION

During the following step, hold unit firmly until window sash is lowered to top channel behind curtain frames. Personal injury or property damage may result if unit falls from window.

Figure 25

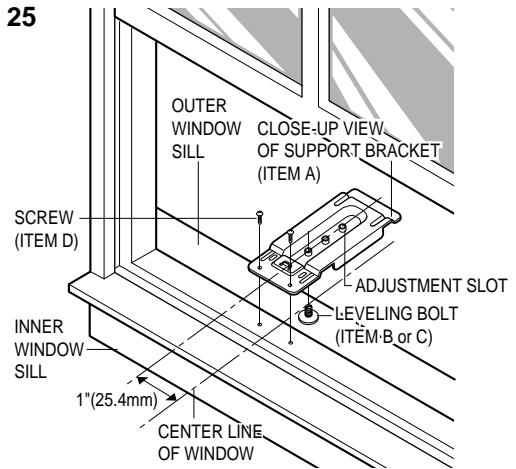

Figure 26

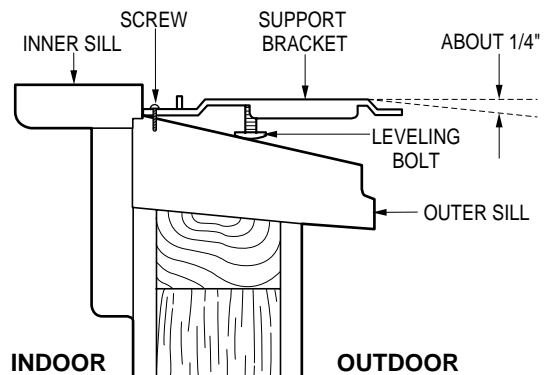

Figure 27

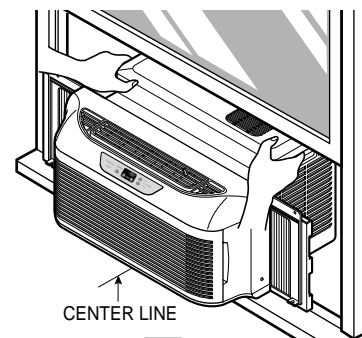
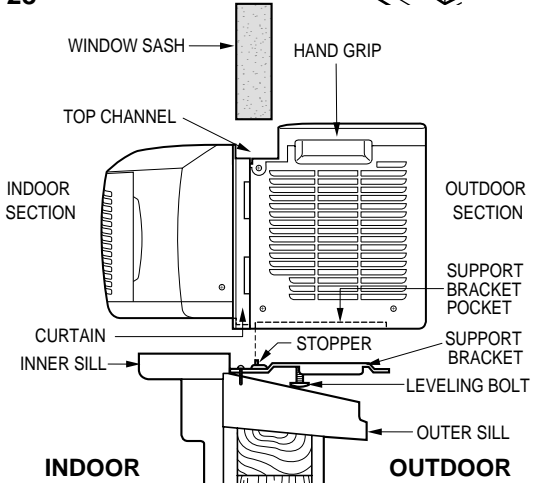

Figure 28



5. SECURE THE CURTAIN FRAMES

Expand the curtain frames and secure them using 5 screws (ITEM E) as shown in Figure 29. When curtain frame opens or closes, you may feel a slight resistance. This is normal.

6. FOAM SEAL AND WINDOW LOCK

- Cut the foam seal (ITEM F) to the window width. Stuff the foam seal between the glass and the window to prevent air and insects from getting into the room, as shown in Figure 29.
- Install the L bracket to prevent window from being raised which may result in unit falling.



CAUTION

Failure to securely install support bracket may result in unit falling from window if window sash is raised after unit is installed. This could result in personal injury.

NOTE: If window sash has a metal surface, use sheet metal screws instead of the provided wood screws. Obtain sheet metal screws at local hardware store.

7. IF AIR CONDITIONER IS BLOCKED BY STORM WINDOW FRAME

- If storm window presents interference, fasten a 2"(51mm) wide wood strip to the inner window sill across the full width of the sill. The wood strip should be thick enough to raise the height of the window sill so that unit can be installed without interference from the the storm window frame. See Figure 30. Top of wood strip should be approximately 3/4"(19mm) higher than the storm window frame to help condensation to drain properly to the outside.
- Install a second wood strip (approximately 6"(152mm) long by 1 1/2"(38mm) wide and same thickness as first strip) in the center of the outer sill flush against the back of the inner sill. (Figure 30)

8. INSTALLATION FOR OTHER TYPE WINDOWS.

- Dimensions and geometry of windows are different depending on their manufacturing. Check your window and refer to FIG.31 to install the support bracket firmly.

Figure 29

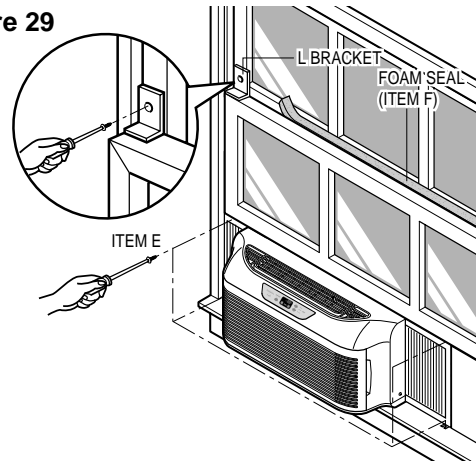
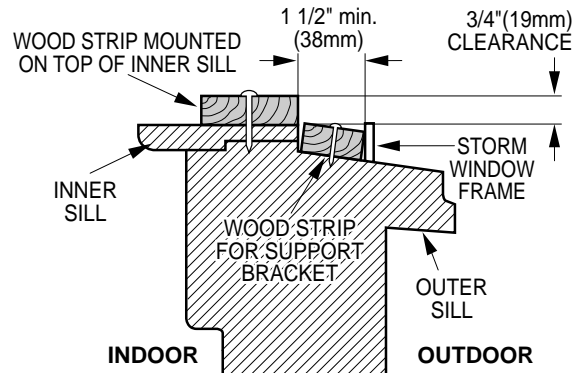

Figure 30



When storm window frame is located on outer sill

(a) When window frame is located on inner sill.

- Install a wood strip (window width long and window frame height high) on the inner sill.

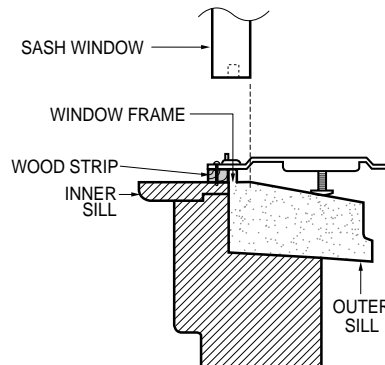

(b) When the window frame is higher than 19/32"(15mm)

- Install a wood strip (about 4"(102mm) long) on the outdoor sill to raise support bracket.

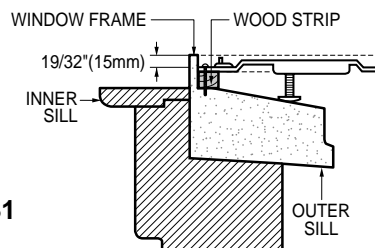

Figure 31

3.7 REMOVAL FROM WINDOW

- Turn off and unplug the air conditioner.
- Unscrew the side screws that you installed in Step 5. 6.
- Close the curtain frame and remove foam seal and L bracket from the windows.
- Keep a firm grip on the air conditioner raise the sash.
- Lift the air conditioner from the window and remove the foam strip from between the windows.
- Remove the support bracket from window frame.

NOTE: When cooling season is over, unit is removed from window for cleaning and storage. There may still be some condensation water in the basepan. Remove the unit carefully to avoid water being spilled out on floor. Always store unit flat on its base. Do not stand on end. Be sure to remove support bracket, L bracket, and foam seal from window and save. Window will not close if support bracket remains installed.

4. TROUBLESHOOTING GUIDE

4.1 OUTSIDE DIMENSIONS

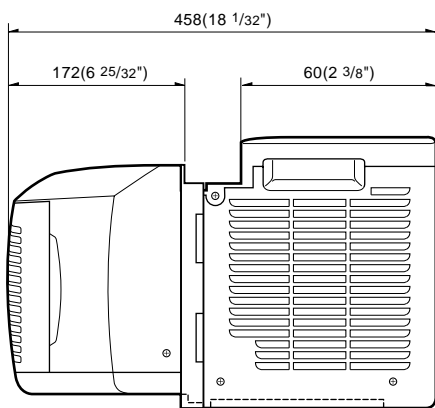

Figure 32

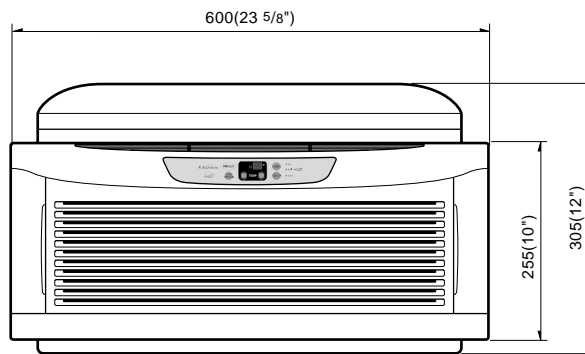

Figure 33

4.2 PIPING SYSTEM

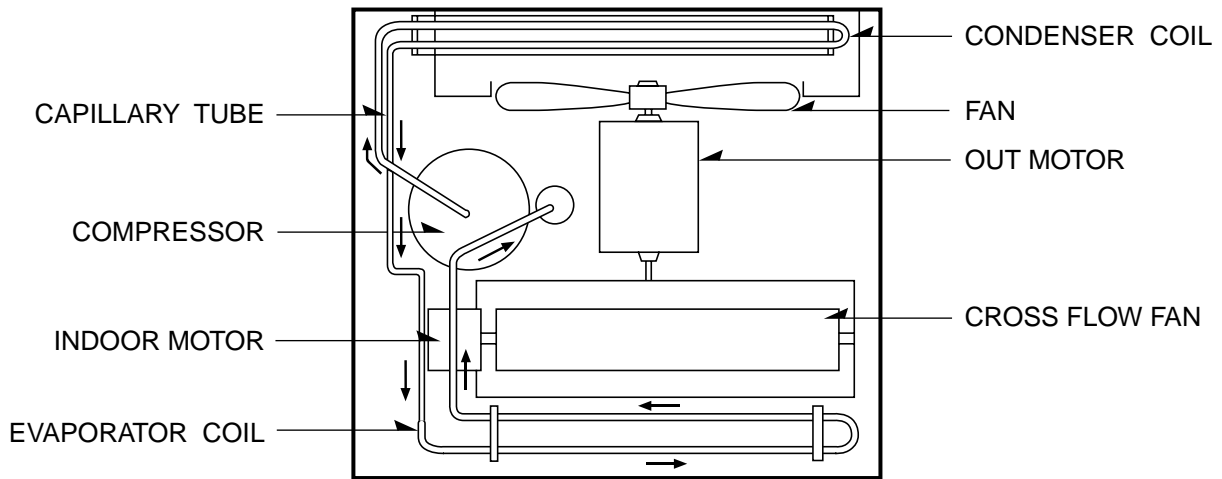

Figure 34

Following is a brief description of the important components and their functions in the refrigeration system. Refer to Figure 35 to follow the refrigeration cycle and the flow of the refrigerant in the cooling cycle.

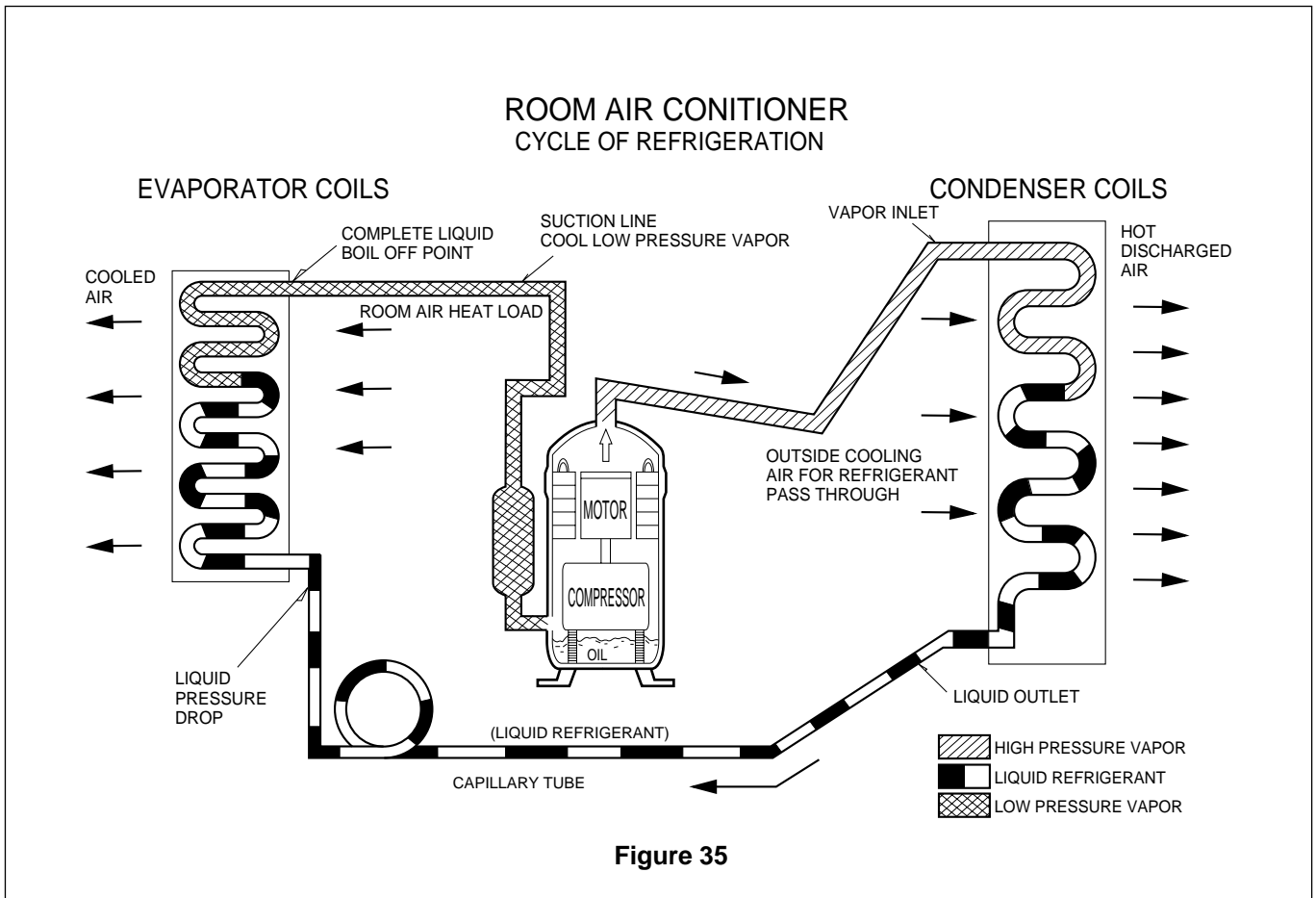
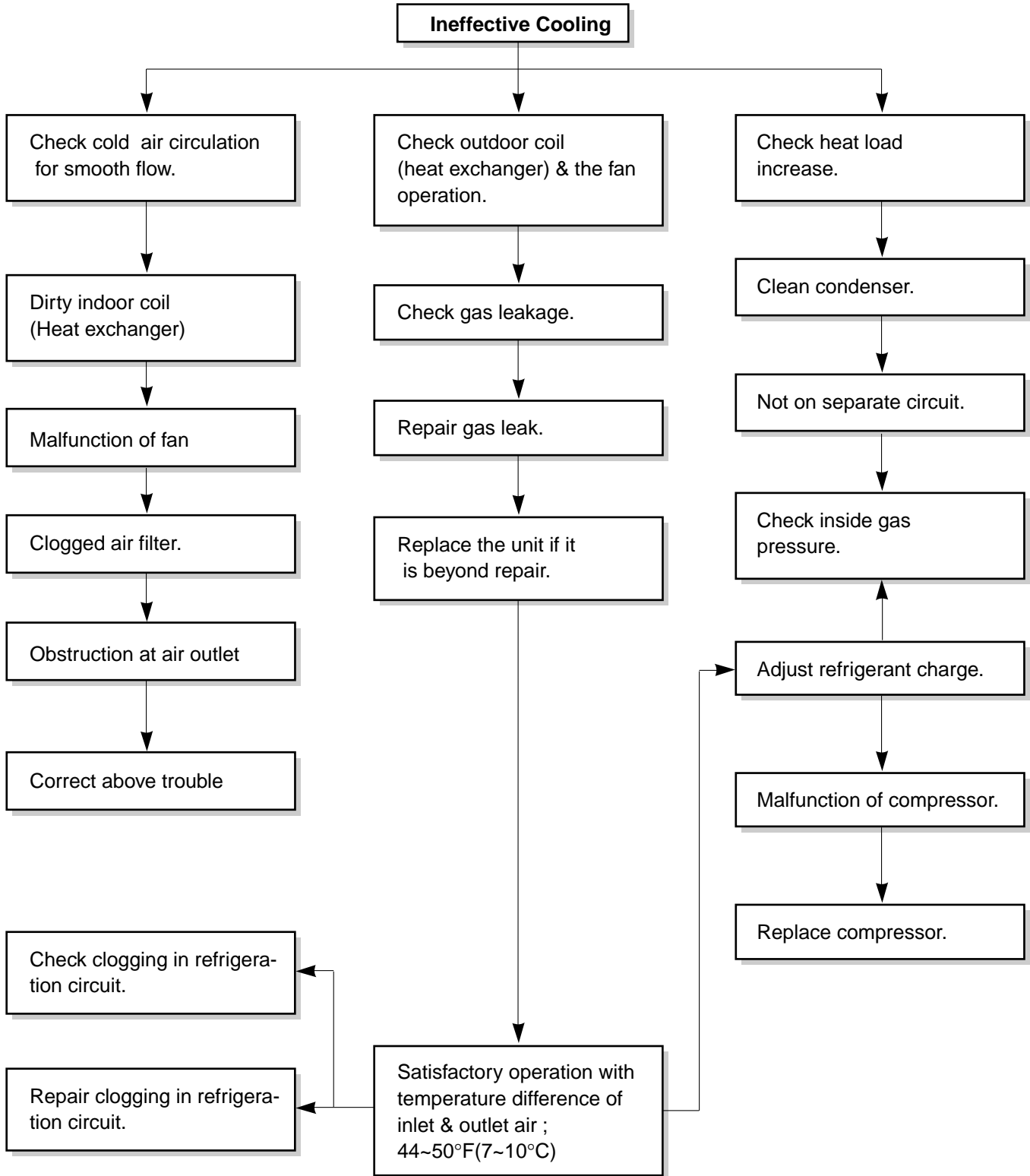

Figure 35

4.3 TROUBLESHOOTING GUIDE

In general, possible trouble is classified within one of two possible categories. The first is designated Starting Failure and is caused from an electrical defect, while the other is ineffective Air Conditioning caused by a defect in the refrigeration circuit or improper application.

Unit runs but cools poorly.



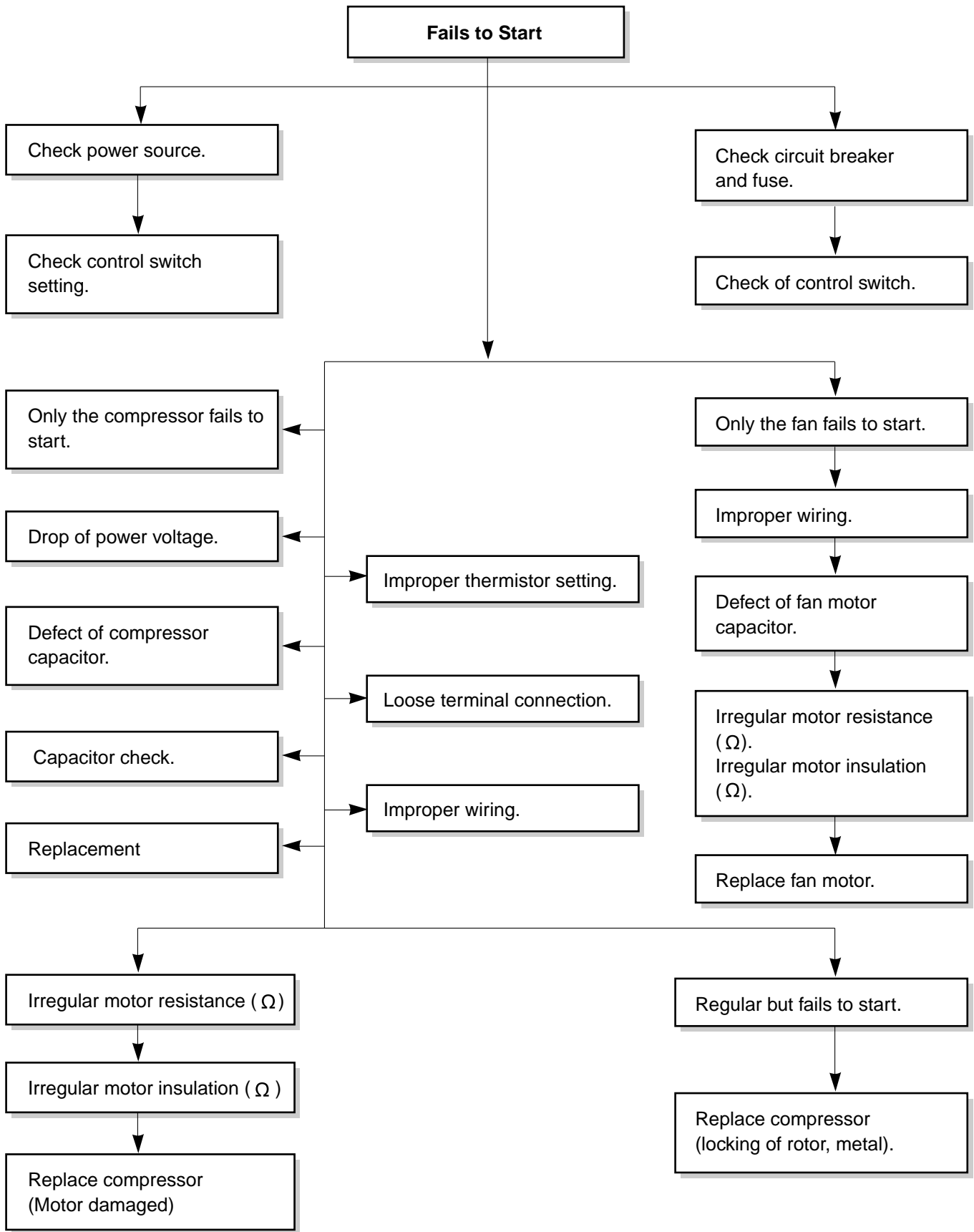

■ ELECTRICAL PARTS TROUBLESHOOTING GUIDE: LP6000ER/LP7000R

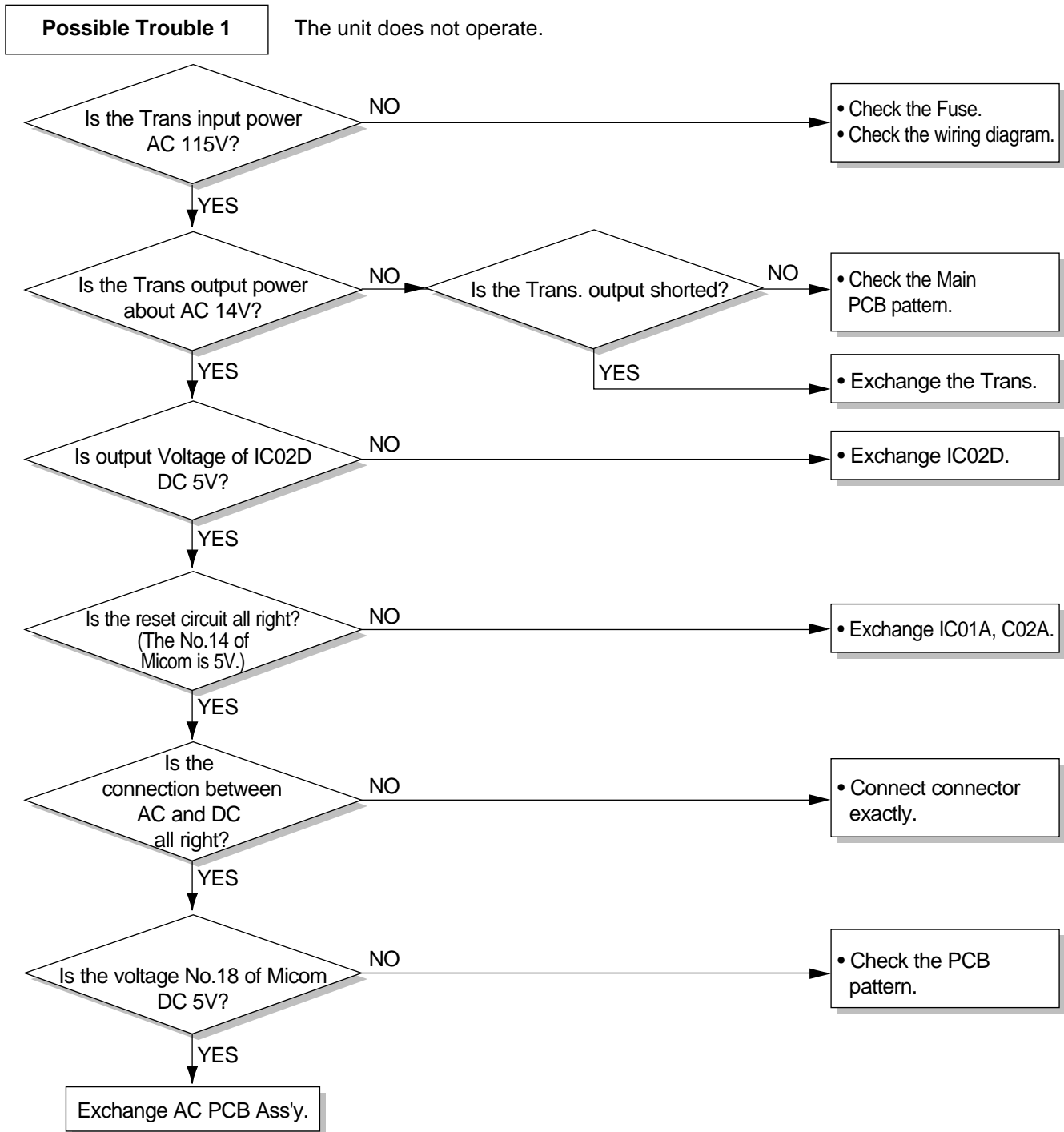

Possible Trouble 2

The compressor does not operate.

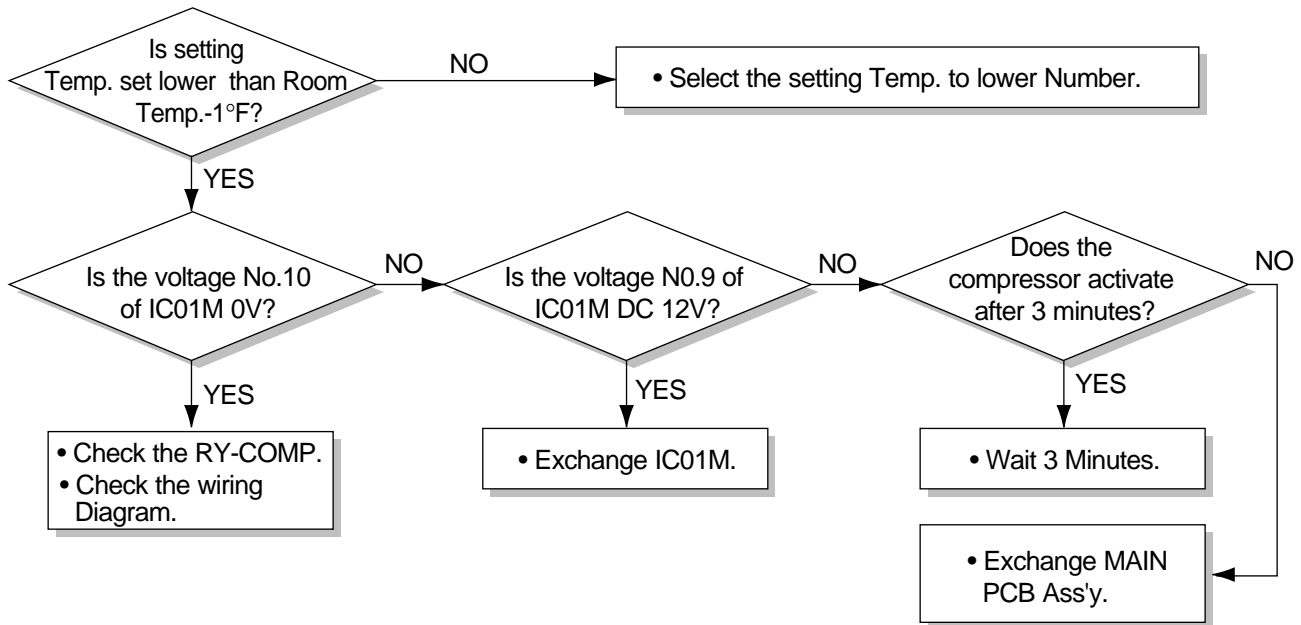

Possible Trouble 3

The compressor always operate.



Possible Trouble 4

FAN does not operate.

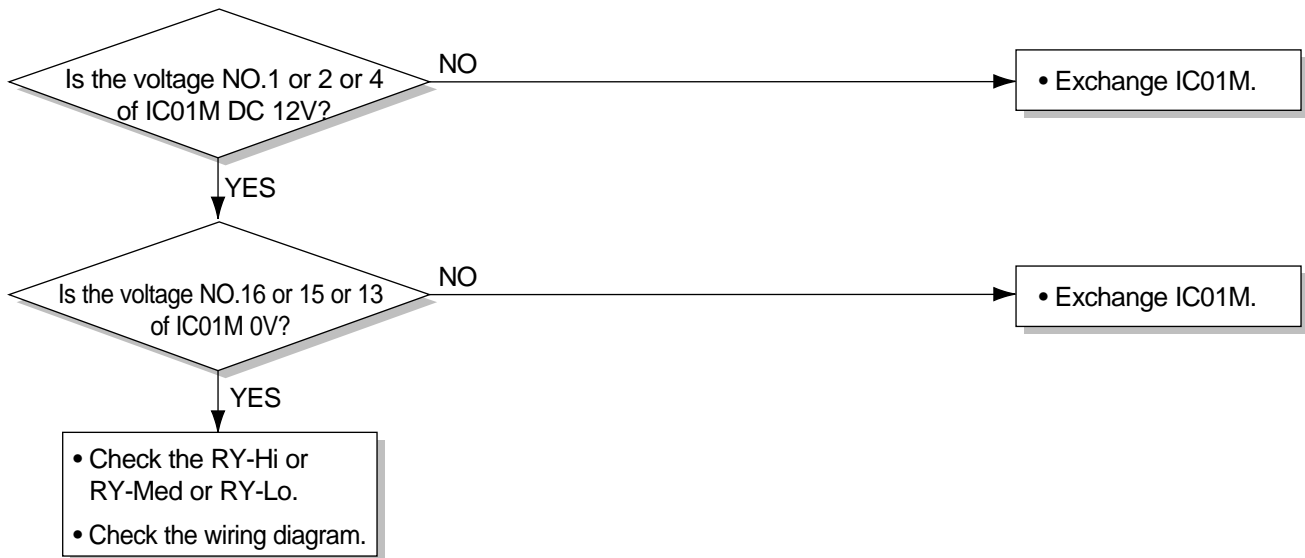
**Possible Trouble 5**

The function of Energy Saver does not operate.

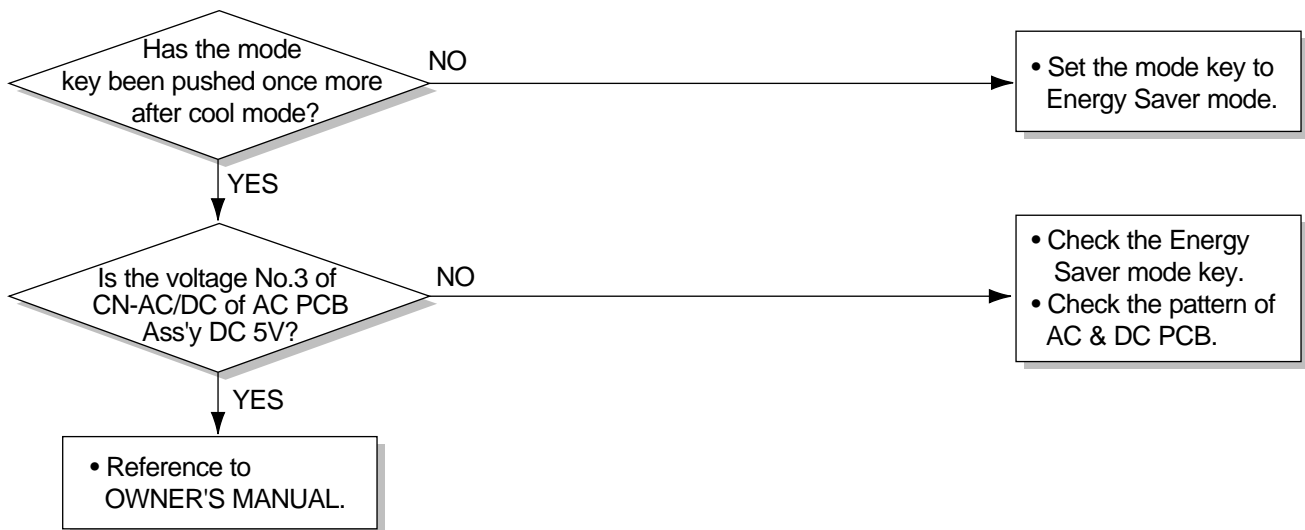

Possible Trouble 6

Remote controller does not operate.

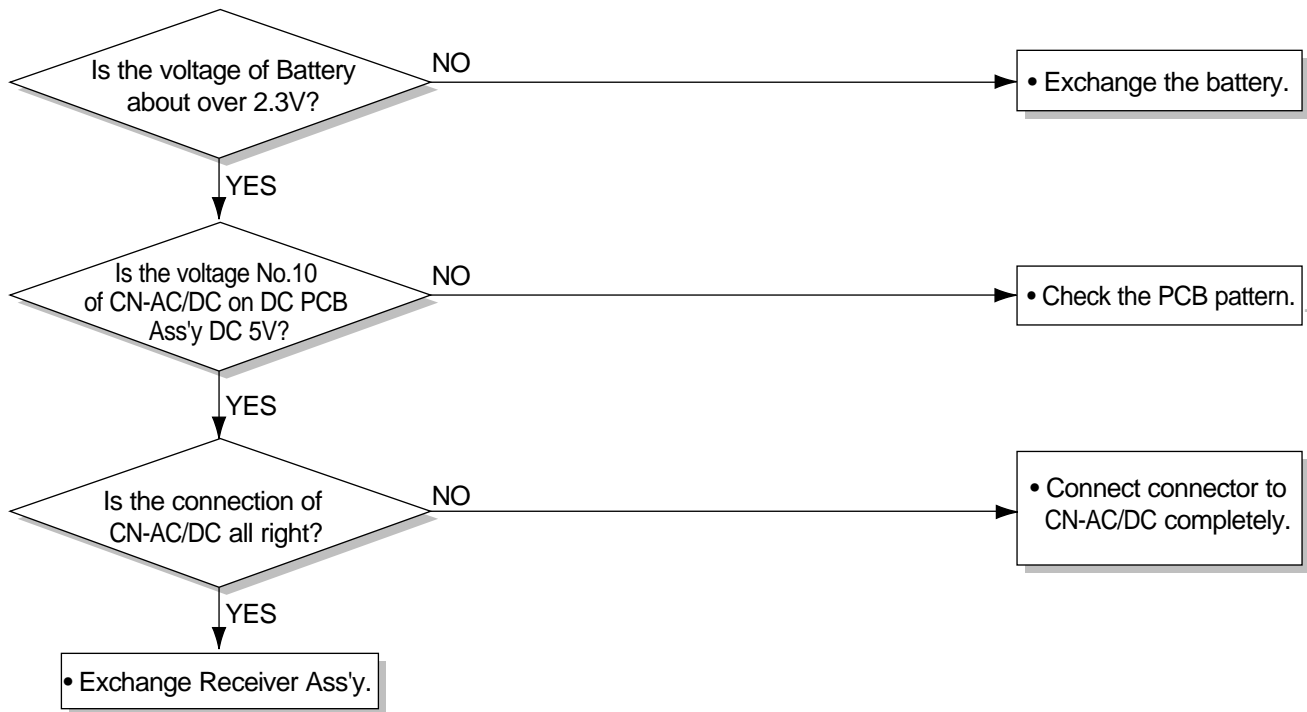
**Possible Trouble 7**

It displays abnormally on DC PCB Ass'y.

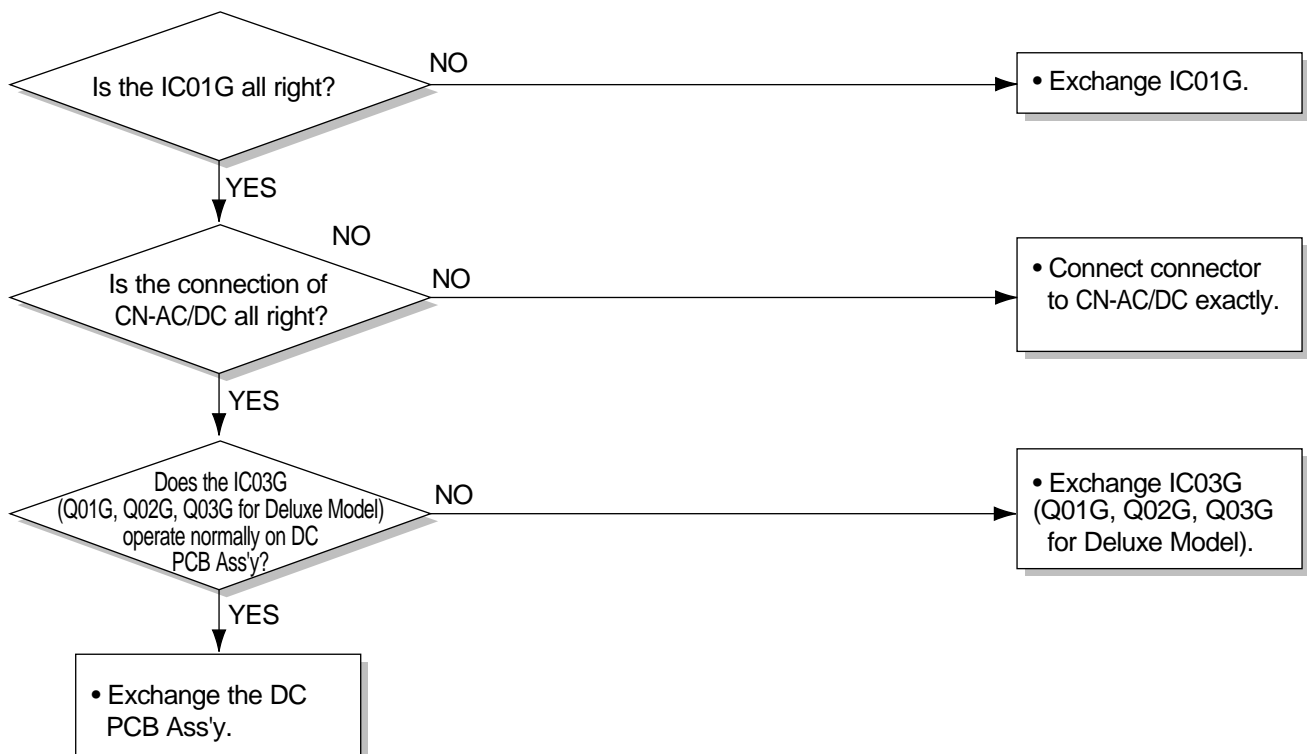

Possible Trouble 8

It displays abnormally on DC PCB Ass'y.

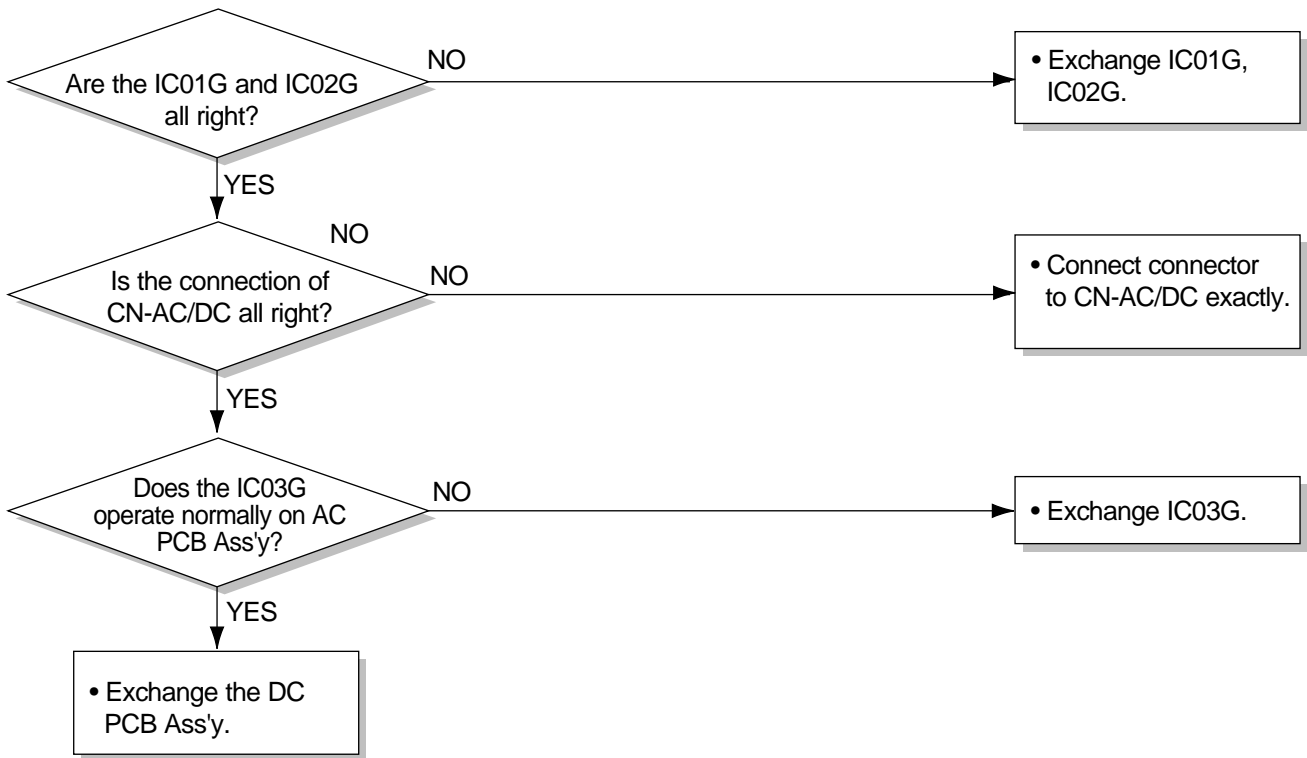

ROOM AIR CONDITIONER VOLTAGE LIMITS

NAME PLATE RATING	MINIMUM	MAXIMUM
115V ±10%	103.5V	126.5V

COMPLAINT	CAUSE	REMEDY
Fan motor will not run.	No power	Check voltage at outlet. Correct if voltage is missing.
	Power supply cord	Check voltage to connector of CN-PWR and 3 port of comp-relay. If none, check power supply cord. Replace cord if circuit is open.
	Wire disconnected or connection loose	Connect wire. Refer to wiring diagram for terminal identification. Repair or replace loose terminal.
	Capacitor (Discharge capacitor before testing.)	Test capacitor. Replace if not within ±10% of manufacturer's rating. Replace if shorted, open, or damaged.
	Will not rotate	Fan blade hitting shroud or blower wheel hitting scroll. Realign assembly. Units using slinger ring for condenser fan must have $\frac{1}{4}$ to $\frac{5}{16}$ inch clearance to the base. If it hits the base, shim up the bottom of the fan motor with mounting screw(s). Check fan motor bearings; if motor shaft will not rotate, replace the motor.
Fan motor runs intermittently	Revolves on overload.	Check voltage. If not within limits, call an electrician. Test capacitor. Check bearings. Does the fan blade rotate freely? If not, replace fan motor. Pay attention to any change from high speed to low speed. If the speed does not change, replace the motor.
Fan motor noise.	Fan	If cracked, out of balance, or partially missing, replace it.
	Cross flow fan	If cracked, out of balance, or partially missing, replace it.
	Loose clamper	Tighten it.
	Worn bearings	If knocking sounds continue when running or loose, replace the motor. If the motor hums or noise appears to be internal while running, replace motor.
Compressor will not run, but fan motor runs.	Voltage	Check voltage. If not within limits, call an electrician.
	Wiring	Check the wire connections, if loose, repair or replace the terminal. If wires are off, refer to wiring diagram for identification, and replace. Check wire locations. If not per wiring diagram, correct.

COMPLAINT	CAUSE	REMEDY
Compressor will not run, but fan motor runs.	Thermistor	Check the status the setting temperature if not lower than room temperature, please decrease the setting temperature. Check continuity of the thermostat. Replace thermostat if circuit is open.
	Capacitor (Discharge capacitor before servicing.)	Check the capacitor. Replace if not within $\pm 10\%$ of manufacturers rating. Replace if shorted, open, or damaged.
	Compressor	Check for compressor for open circuit or ground. If open or grounded, replace the compressor.
	Overload	Check the compressor overload, if externally mounted. Replace if open. (If the compressor temperature is high, remove the overload, cool it, and retest.)
Compressor cycles on overload.	Voltage	Check the voltage. If not within limits, call an electrician.
	Overload	Check overload, if externally mounted. Replace if open. (If the compressor temperature is high, remove the overload, cool, and retest.)
Compressor cycles on overload.	Fan motor	If not running, determine the cause. Replace if required.
	Condenser air flow restriction	Remove the cabinet. inspect the interior surface of the condenser; if restricted, clean carefully with a vacuum cleaner (do not damage fins) or brush. Clean the interior base before reassembling.
	Condenser fins (damaged)	If condenser fins are closed over a large area on the coil surface, head pressures will increase, causing the compressor to overload. Straighten the fins or replace the coil.
Compressor cycles on overload.	Capacitor	Test capacitor.
	Wiring	Check the terminals. If loose, repair or replace.
	Refrigerating system	Check the system for a restriction.
Insufficient cooling or heating	Air filter	If restricted, clean or replace.
	Exhaust damper door	Close if open.
	Unit undersized	Determine if the unit is properly sized for the area to be cooled.
Excessive noise	Cross flow fan or fan	Check the set screw or clamp. If loose or missing, correct. If the blower or fan is hitting air guide, rearrange the air handling parts.
	Copper tubing	Remove the cabinet carefully and rearrange tubing not to contact cabinet, compressor, shroud, and barrier.

5. SCHEMATIC DIAGRAM

5.1 CIRCUIT DIAGRAM

■ MODEL : LP6000ER/LP7000R

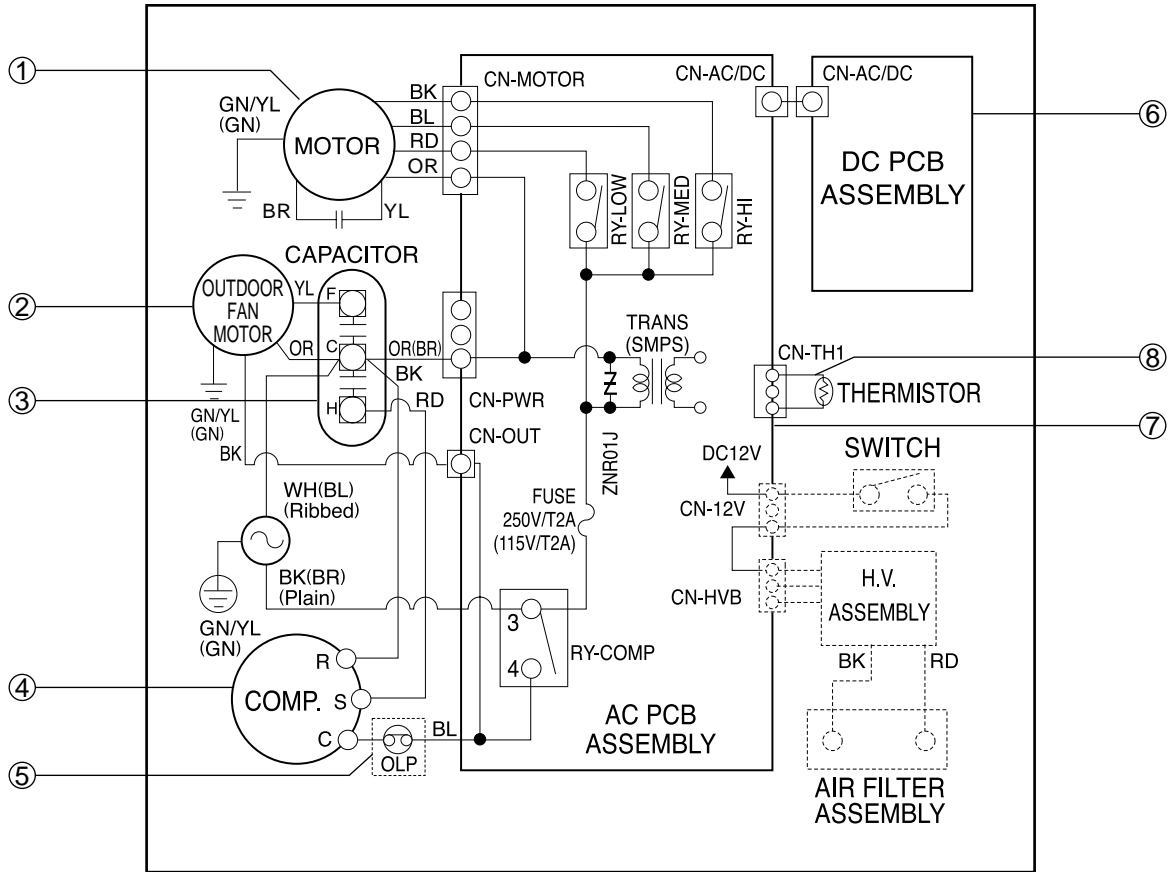

S: Service Parts
N: Non Service Parts

LOCATION NO.	DESCRIPTION	PART NO.		Q'TY PER SET	RE-MARKS
		LP6000ER	LP7000R		
1	INDOOR MOTOR ASSY	4681A20088A		1	S
2	OUTDOOR MOTOR ASSY	4681A20089A		1	S
3	CAPACITOR	6120AR2359V	0CZZA20001W	1	S
4	COMPRESSOR	2520UABC2JA	2520UAEC2CB	1	S
5	OVERLOAD PROTECTOR	6750U3L001A	6750U-L060A	1	S
6	DC PCB ASSEMBLY	6871A20342A		1	S
7	AC PCB ASSEMBLY	6871A20343A		1	S
8	THERMISTOR	6323A20004E		1	S

5.2 ELECTRONIC CONTROL DEVICE

■ MODEL: LP6000ER/LP7000R

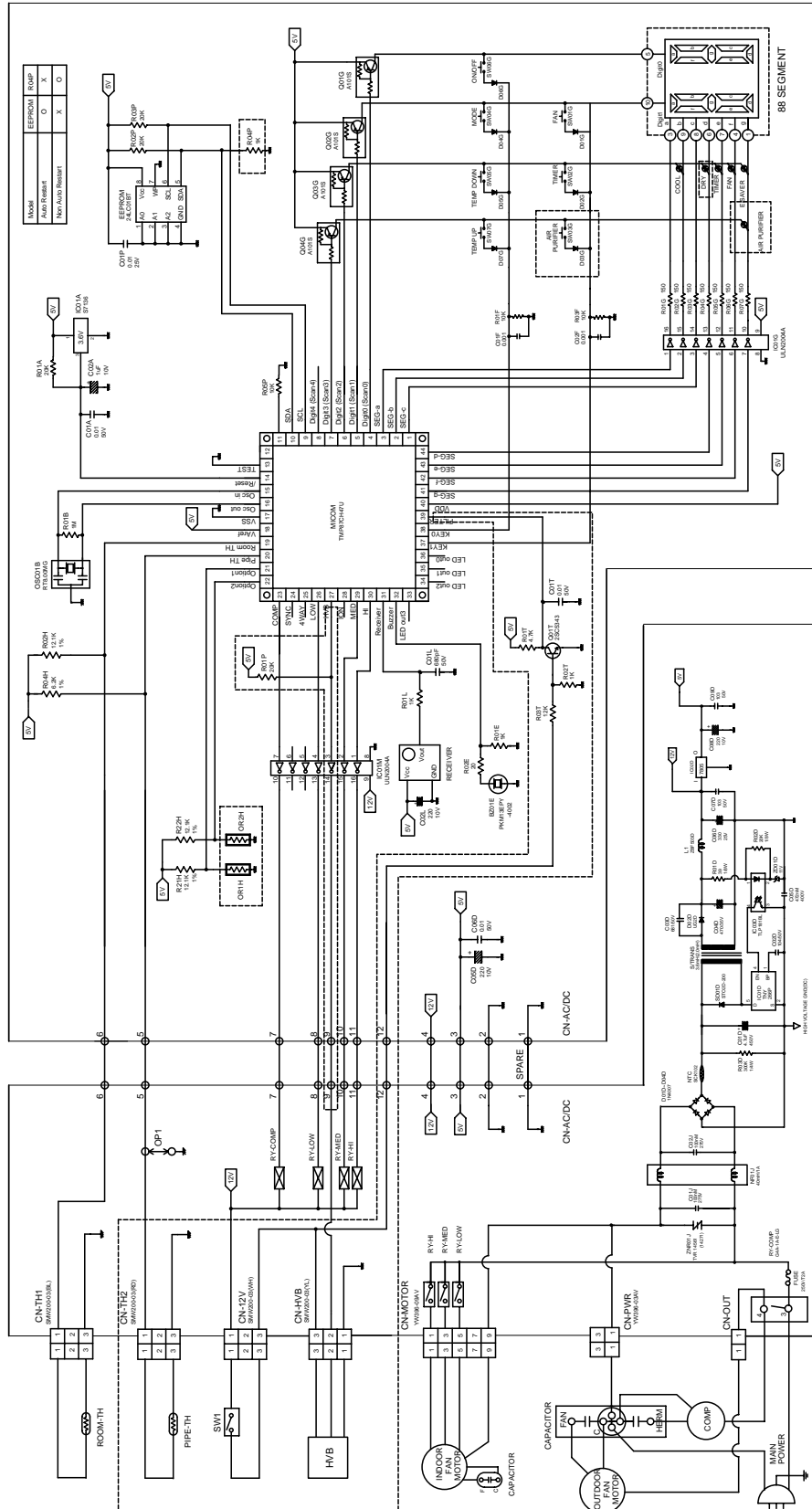

6. EXPLODED VIEW

■ Model: LP6000ER/LP7000R

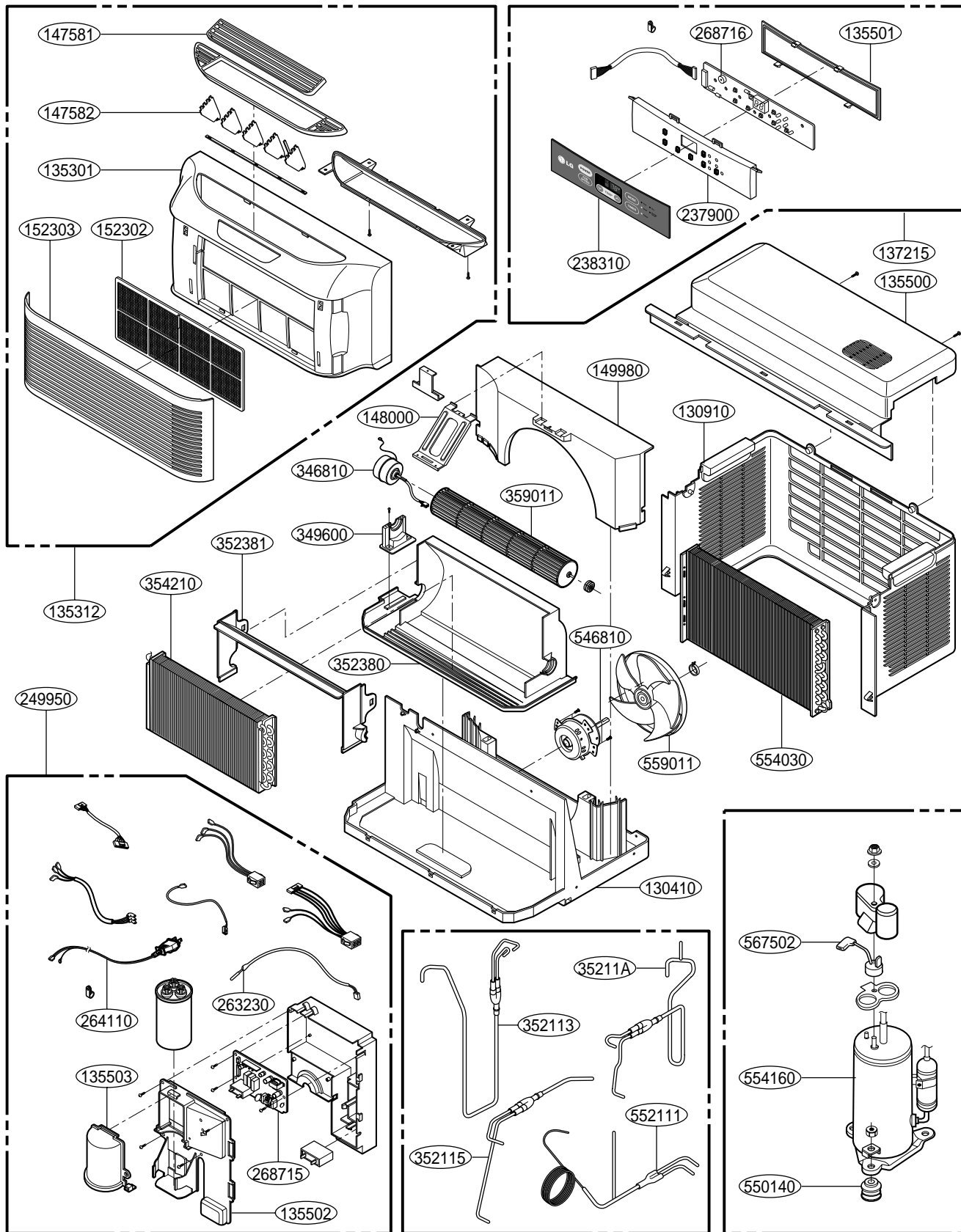

7. REPLACEMENT PARTS LIST

• MODEL: LP6000ER/LP7000R

R: Service Parts
N: Non Service Parts

LOCATION NO.	DESCRIPTION	PART NO.		REMARK
		LP6000ER	LP7000R	
130410	BASE ASS'Y, SINGLE	3041A20041A		R
130910	CABINET ASS'Y	3091A20017B		R
135301	FRONT GRILLE	3530A10153A		R
135303	INLET GRILLE	3530A10158A		R
135312	FRONT GRILL ASS'Y	3531A20168C	3531A20168B	R
135500	TOP COVER	3550A20202B		R
135501	COVER DISPLAY	3550A20200A		R
135502	COVER, CONTROL BOX	3550A20201A		R
135503	COVER, CAPACITOR	3550A20209A		R
137215	CONTROL PANEL ASS'Y	3721A20133C	3721A20133B	R
147581	DISCHARGE GRILLE(HORIZONTAL LOUVER)	3530A20078A		R
147582	VERTICAL LOUVER	4758A30037A / 4758A30037B		R
148000	BRACE	4800A20004A		R
149980	SHROUD	4998A20002A		R
152302	AIR FILTER ASS'Y	5230A20031A		R
237900	WINDOW DISPLAY	3790A20065A		R
238310	ESCUTCHEON	3831A20055C	3831A20055B	R
249950	CONTROL BOX ASS'Y	4995A20277A	4995A20277B	R
263230	THERMISTOR ASS'Y	6323A20004E		R
264110	POWER CORD ASS'Y	6411A20011W		R
268715	MAIN PCB ASS'Y(AC)	6871A20343A		R
268716	DISPLAY PCB ASS'Y(DC)	6871A20342A		R
346810	INDOOR MOTOR ASS'Y	4681A20088A		R
349600	MOUNT MOTOR	4960A20045A		R
35211A	SUCTION TUBE ASS'Y	5211A20831A		R
352113	TUBE ASS'Y, DISCHARGE	5211A20832A		R
352115	TUBE ASS'Y EVAPORATOR	5211A20834A	5211A20834B	R
352380	AIR GUIDE LOWER	5238A20022A		R
352381	AIR GUIDE UPPER	5238A20021A		R
354210	EVAPORATOR ASS'Y	5421A20137B		R
359011	CROSS FLOW FAN	5901A20020A		R
546810	OUTDOOR MOTOR ASS'Y	4681A20089A		R
550140	ISOLATOR, COMP	5040AR4195A		R
552111	TUBE ASS'Y, CONDENSER OUT	5211A20879A	5211A20879B	R
554030	CONDENSER ASS'Y	5403A20117A	5403A20117B	R
554160	COMPRESSOR	2520UABC2JA	2520UAEC2CB	R
559011	FAN	5900A20006A		R
567502	OVERLOAD PROTECTOR	6750U3L001A	6750U-L060A	R
W0CZZ	CAPACITOR	6120AR2359V	0CZZA20001W	R

MEMO

A series of horizontal dotted lines for writing.

MEMO

A series of horizontal dotted lines for writing.

